



Series R™ Helical-Rotary Liquid Chillers

Model RTWB 207-224

200-700 kW

Condenserless Model RTUB 207-224

200-700 kW

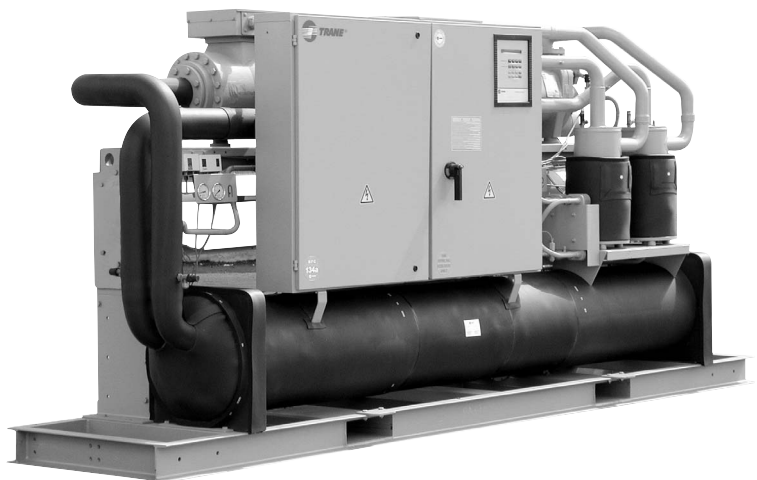

RLC-PRC002-E4

Model Number Description

Digit 1-2-3-4-5: Unit model type

ERTWB: Epinal RTWB

ERTUB: Epinal RTUB

Digit 6-7-8: Unit size

207-208-210-211-212-214-216-217-218-220-222-224

Digit 11: Approval

2: Pressure European Directive

D: Australia

V: Poland

Digit 12: Language

C: Spanish

D: German

E: English

F: French

H: Dutch

I: Italian

M: Swedish

U: Greek

V: Portuguese

Digit 15: Main power voltage

C: 380/50/3

D: 400/50/3

E: 415/50/3

S: Special

Digit 17: Electrical codes

A: IEC

S: Special

Digit 18: Compressor starter

H: Unit-mounted star-delta

S: Special

Digit 20: Main electrical disconnect device

X: Without

B: Fused disconnect switch

S: Special

Digit 23: Leaving chilled-water temperature

A: $-12^{\circ}\text{C} \leq \text{T}^{\circ}\text{C} < -8^{\circ}\text{C}$

B: $-8^{\circ}\text{C} \leq \text{T}^{\circ}\text{C} < -4^{\circ}\text{C}$

C: $-4^{\circ}\text{C} \leq \text{T}^{\circ}\text{C} < +4^{\circ}\text{C}$

D: $+4^{\circ}\text{C} \leq \text{T}^{\circ}\text{C} < +10^{\circ}\text{C}$

E: $+10^{\circ}\text{C} \leq \text{T}^{\circ}\text{C} \leq +15^{\circ}\text{C}$

S: Special

Digit 25: Condenser size

X: Without (RTUB)

2: Standard (RTWB)

Digit 26: Condenser leaving water temperature (RTWB)
Saturated condenser temperature (RTUB)

A: $25^{\circ}\text{C} \leq \text{T}^{\circ}\text{C} < 30^{\circ}\text{C}$ (RTWB)

B: $30^{\circ}\text{C} \leq \text{T}^{\circ}\text{C} < 35^{\circ}\text{C}$ (RTWB/UB)

C: $35^{\circ}\text{C} \leq \text{T}^{\circ}\text{C} < 40^{\circ}\text{C}$ (RTWB/UB)

D: $40^{\circ}\text{C} \leq \text{T}^{\circ}\text{C} < 45^{\circ}\text{C}$ (RTWB/UB)

E: $45^{\circ}\text{C} < \text{T}^{\circ}\text{C} \leq 50^{\circ}\text{C}$ (RTWB/UB)

F: $50^{\circ}\text{C} \leq \text{T}^{\circ}\text{C} \leq 55^{\circ}\text{C}$ (RTWB/UB)

G: $55^{\circ}\text{C} \leq \text{T}^{\circ}\text{C} \leq 60^{\circ}\text{C}$ (RTWB/UB)

H: $60^{\circ}\text{C} < \text{T}^{\circ}\text{C} \leq 65^{\circ}\text{C}$ (RTUB)

S: Special

Digit 27: Condenser tubes

X: Without

5: GEWA C

S: Special

Digit 28: Condenser pass

X: Without (RTUB)

A: 1 pass

B: 2 pass right

C: 2 pass left

S: Special

Digit 31: Operating conditions

A: One only

S: Special

Digit 44: Under-over voltage protection

X: Without

1: With

Digit 45: IP 20 protection

X: Without

1: With

Digit 49: Communication cards

X: Without

1: CSR module

2: 1+ temperature sensor

3: 2+ LWTC control

Digit 52: Compressor sound attenuating enclosure

X: Without

1: With

Digit 53: Pressure gauges

X: Without

1: With

Digit 56: Compressor isolator valve

X: Without

1: Discharge (RTWB only)

Digit 57: Ammeter/voltmeter

X: Without

1: With

Digit 61: Safety devices

X: Standard

1: Germany

3: Netherlands

Digit 64: Packing

1: Domestic

2: SEI Class 3

3: SEI Class 4a

4: SEI Class 4c

S: Special

Digit 65: Isolators

X: Without

1: Pads

S: Special

Digit 66: Flow switch

X: Without

1: Quantity 1

2: Quantity 2

Digit 67: Counterflanges

X: Without

1: With

Digit 71: Temperature sensors

X: Without

1: With

Digit 74: Factory test

X: (RTUB)

A: A (RTWB)

B: B (RTWB/UB)

E: E (RTWB)

S: Special

Digit 75: Other special requirement(s)

X: No

S: Yes

Performance Data

Performance data RTUB

Model RTUB	Leaving chilled-water temperature (°C)	Condensing temperature (°C)					
		40		50		60	
		Cooling capacity (kW)	Power input (kW)	Cooling capacity (kW)	Power input (kW)	Cooling capacity (kW)	Power input (kW)
207	5	205	48	181	57	152	69
	7	221	49	195	58	164	70
	9	237	50	210	59	177	71
208	5	242	57	214	67	181	81
	7	260	58	231	69	195	83
	9	278	60	248	70	210	84
210	5	306	74	270	87	231	104
	7	329	76	291	89	249	106
	9	352	78	312	91	269	107
211	5	323	79	286	93	246	111
	7	347	81	308	95	266	113
	9	372	83	331	97	287	115
212	5	347	85	308	100	265	119
	7	372	87	331	102	287	121
	9	399	89	356	103	309	123
214	5	423	94	376	111	326	133
	7	455	96	405	113	352	135
	9	488	98	436	115	379	137
216	5	461	102	411	121	356	145
	7	495	105	442	123	385	147
	9	531	107	475	125	415	149
217	5	499	111	445	132	387	158
	7	536	113	479	134	418	160
	9	574	116	514	136	450	162
218	5	536	124	480	147	419	175
	7	575	127	515	149	451	178
	9	615	130	553	152	486	181
220	5	585	139	524	163	458	195
	7	627	142	563	167	493	198
	9	671	146	603	170	530	201
222	5	684	157	614	183	537	216
	7	734	161	660	187	579	220
	9	786	165	708	191	623	224
224	5	742	171	668	199	588	236
	7	796	176	718	204	633	240
	9	852	181	770	208	680	244

Evaporator deltaT 5°C, sub-cooling 9.6°C, fouling factor 0.0176 m²K/kW, standard evaporators electrical voltage frequency 50Hz, refrigerant R134a.

General Data

Model RTWB	Evaporator code	Condenser code	Evaporator water content (l)	Condenser water content (l)
207	EG 120	CG 120	105	60
208	EG 120	CG 120	105	60
210	EG 140	CG 140	265	55
211	EG 170	CG 170	220	66
212	EG 170	CG 170	220	66
214	EG 200	CG 200	200	75
216	EG 200	CG 200	200	75
217	EG 200	CG 200	200	75
218	EG 250	CG 230	415	78
220	EG 250	CG 230	415	78
222	EG 340	CG 230	560	78
224	EG 340	CG 230	560	78

Model RTWB	Refrigerant	Number of circuits	Unit refrigerant charge (kg)	Unit oil charge (l)
207	R134a	2	78	12
208	R134a	2	78	12
210	R134a	2	120	14
211	R134a	2	120	14
212	R134a	2	120	14
214	R134a	2	120	16
216	R134a	2	120	16
217	R134a	2	120	16
218	R134a	2	138	16
220	R134a	2	138	16
222	R134a	2	148	19
224	R134a	2	148	22

Model RTUB	Evaporator code	Evaporator water content (l)	Refrigerant	Number of circuits	Unit refrigerant charge (kg)	Unit oil charge (l)
207	EG 120	105	R134a	2	26	12
208	EG 120	105	R134a	2	26	12
210	EG 140	265	R134a	2	40	14
211	EG 170	220	R134a	2	40	14
212	EG 170	220	R134a	2	40	14
214	EG 200	200	R134a	2	40	16
216	EG 200	200	R134a	2	40	16
217	EG 200	200	R134a	2	40	16
218	EG 250	415	R134a	2	46	16
220	EG 250	415	R134a	2	46	16
222	EG 340	560	R134a	2	50	19
224	EG 340	560	R134a	2	50	22

General Data

Minimum and maximum evaporator water flow RTWB/RTUB

Evaporator code	Pass number	Minimum water flow (l/s)	Maximum water flow (l/s)	Connection Diameter (inch)
EG 120	1	4.5	13.4	5
EG 140	1	6.0	18.0	6
EG 170	1	7.0	21.0	6
EG 200	1	9.0	25.0	6
EG 250	1	11.0	33.0	6
EG 340	1	14.0	43.0	6

Minimum and maximum condenser water flow RTWB

Condenser code	Pass number	Minimum water flow (l/s)	Maximum water flow (l/s)	Connection diameter (inch)
CG 120	1	8.4	31.0	5
CG 140	1	9.5	34.9	5
CG 170	1	11.9	43.7	5
CG 200	1	17.0	61.0	5
CG 230	1	17.0	61.0	5

RTWB/RTUB Evaporator water pressure drop (kPa)

Model RTWB/RTUB	Pass Number	Water flow (L/s)								
		5	10	15	20	25	30	35	40	45
207	1	6	24							
208	1	6	24							
210	1		57	122						
211	1		29	61	104					
212	1		29	61	104					
214	1		11	24	41	62				
216	1		11	24	41	62				
217	1		11	24	41	62				
218	1			17	29	45	64			
220	1			17	29	45	64			
222	1				23	35	49	66	85	106
224	1				23	35	49	66	85	106

RTWB Condenser water pressure drop (kPa)

Model RTWB	Pass Number	Water flow (L/s)										
		10	15	20	25	30	35	40	45	50	55	60
207	1	10	20	34	51	71						
208	1	10	20	34	51	71						
210	1	6	12	20	30	42						
211	1		8	14	21	29	38	48				
212	1		8	14	21	29	38	48				
214	1			12	18	24	32	40	48	58	68	79
216	1			12	18	24	32	40	48	58	68	79
217	1			12	18	24	32	40	48	58	68	79
218	1			12	18	24	32	40	48	58	68	79
220	1			12	18	24	32	40	48	58	68	79
222	1			12	18	24	32	40	48	58	68	79
224	1			12	18	24	32	40	48	58	68	79

Controls

The RTWB and RTUB water-cooled Series R chillers employ the most advanced controls on the market today. The two-line forty-character Clear Language Display (CLD) has a backlight for a simple readout.

Adaptive Control™ microcomputer

The microcomputer-based controller optimizes controls around the chiller application and the specific components used in the Series R chiller. For instance, the compressor protection system is specifically designed for the Series R unit. A leaving chilled-water temperature-control algorithm maintains accurate temperature control, minimizes the drift from the setpoint and provides better building comfort. The microprocessor control incorporates improved chiller start-up, load limiting, lead/lag and compressor run-time equalization functions into standard chiller operation. The interface with building automation systems remains flexible and easy.

Safety controls

A centralized microcomputer provides a high level of machine protection. The safety controls are designed to avoid compressor and/or evaporator operation failures and to minimize nuisance shutdowns. The Unit Control Module (UCM) directly senses the control variables that govern the operation of the chiller: motor current draw, evaporator temperature, and condenser temperature. When any one of the variables approaches a limit condition where the chiller may be shutdown to avoid damage, the UCM takes corrective action to avoid shutdown and keep the chiller operating. Corrective action is accomplished through combined actions on the compressor unloader valve and on the electronic expansion valve.

Additionally, the UCM optimizes the total power consumption of the chiller during normal operating conditions. During abnormal operating conditions, the UCM will continue to optimize the chiller performances by taking the necessary corrective action to avoid shutdown. This keeps cooling capacity available until the problem

can be solved. Whenever possible, the chiller is allowed to perform its function: making chilled-water. In addition, microcomputer control provides safety protections such as under/over voltage (option), phase reversal, phase loss, phase imbalance, low voltage and overload protection. These safety controls help the chiller to remain in operation and keep all of the building occupants comfortable.

Monitoring and diagnostics

Because the microcomputer provides all control functions, it can easily indicate such parameters as leaving chilled-water temperature. All of the monitoring and diagnostic information is displayed directly on a clear language microcomputer display. If a failure does occur, one of many Clear Language Display messages will indicate the problem.

Standard features

External Auto/Stop

A job-site-provided contact closure will turn the chiller on and off. Note: do not use the chilled-water pump to stop the chiller.

External interlock

A job-site-supplied contact opening wired to this input will turn the chiller off and will require a manual reset of the chiller microcomputer. This closure is typically triggered by a job-site-supplied system such as a fire alarm.

Chilled-water pump control

Unit control provides output to control the chilled-water pump(s). One contact closure to the chiller is all that is required to initiate the chilled-water system.

Optional features

Communication interface

Capability for communication with the following control device:

Trane Tracer building automation systems

External chilled-water setpoint

Allows the external setting independent of the front panel point by one of the following means: a) a remote resistor input (fixed or

adjustable), b) a 2-10 Vdc input or, c) a 4-20 mA input.

External current limit setpoint

Allows the external setting independent of the front panel point by one of the following means: a) a remote resistor input (fixed or adjustable), b) a 2-10 Vdc input or, c) a 4-20 mA input.

Remote running and alarm indication contacts

The chiller provides three single-pole double-throw contact closures to indicate that a failure has occurred if any compressors are running, or if the compressors are running at maximum capacity. These contact closures may be used to trigger job-site-supplied alarm lights or bells.

Ice-making control

Provides an interface with ice-making controls systems.

Chilled-water temperature reset

Reset can be based on return water temperature or outdoor air temperature.

The next version reviews the recommended interface with the following control systems: Integrated Comfort systems interface, non-Trane building automation systems, stand-alone chillers, and ice-making systems.

Trane Integrated Comfort system (ICS) interface

A single twisted pair of wires ties directly between the chiller and a Tracer™ system. A Tracer system provides elaborate control, monitoring and diagnostic capabilities. When the Series R chillers are used in conjunction with a Trane Tracer system, the chiller can be monitored and controlled from a remote location. The Series R chiller can be controlled to fit into the overall building automation strategy by using time-of-day scheduling, timed override, demand limiting and chiller sequencing. A building owner can completely monitor the Series R chiller from the Tracer system, because all of the monitoring information indicated on the microcomputer can be read on the Tracer system display. In addition, all

Electrical Data and Connections - RTWB/RTUB

Compressor motor electrical data - 50 Hz-

Model RTWB/RTUB	Nominal voltage (V/Ph/Hz)	Maximum unit kW (kW)	Maximum RLA (1) (A)	Starting amps (2) (A)	Power factor
207	400/3/50	90	147	170	0.91
208	400/3/50	106	170	196	0.92
210	400/3/50	132	215	228	0.90
211	400/3/50	142	235	264	0.89
212	400/3/50	153	255	279	0.88
214	400/3/50	182	297	332	0.89
216	400/3/50	202	329	374	0.90
217	400/3/50	222	360	398	0.90
218	400/3/50	243	396	430	0.89
220	400/3/50	264	432	457	0.89
222	400/3/50	292	477	520	0.89
224	400/3/50	319	521	554	0.89

(1) To take in account for the sizing of power cables

(2) Star-delta start - one compressor at full load, the other starting

General electrical data

Model RTWB/RTUB	Nominal voltage (V/Ph/Hz)	Crankcase heater		Control circuit	Short circuit intensity (kA)	Remaining intensity (1) (A)
		Oil separator (W)	Compressor (W)			
207	400/3/50	2 x 125	2 x 150	Factory-installed transformer	35	100
208	400/3/50	2 x 125	2 x 150		35	80
210	400/3/50	2 x 125	2 x 150		35	40
211	400/3/50	2 x 125	2 x 150		35	90
212	400/3/50	2 x 125	2 x 150		35	60
214	400/3/50	2 x 125	2 x 150		35	122
216	400/3/50	2 x 125	2 x 150		35	97
217	400/3/50	2 x 125	2 x 150		35	72
218	400/3/50	2 x 125	2 x 150		35	132
220	400/3/50	2 x 125	2 x 150		35	92
222	400/3/50	2 x 125	2 x 150		35	179
224	400/3/50	2 x 125	2 x 150		35	136

(1) Remaining intensity of the chiller disconnect switch: available to connect auxiliary devices such as water pumps.

Electrical connection

Model RTWB/RTUB	Fuse size (1) (A)	Disconnect switch size (1) (A)	Minimum connecting wire (1) (mm ²)	Maximum connecting wire (1) (mm ²)
207	80	315	150	240
208	100	315	150	240
210	125	315	150	240
211	60+125	400	185	240
212	160	400	185	240
214	2 x 160	400	185	240
216	160+200	630	2x150	2x300
217	2 x 200	630	2x150	2x300
218	250+200	630	2x150	2x300
220	2 x 250	630	2x150	2x300
222	2 x 315	800	2x185	2x300
224	2 x 315	800	2x185	2x300

(1) With disconnect switch option only.

Job Site Connections

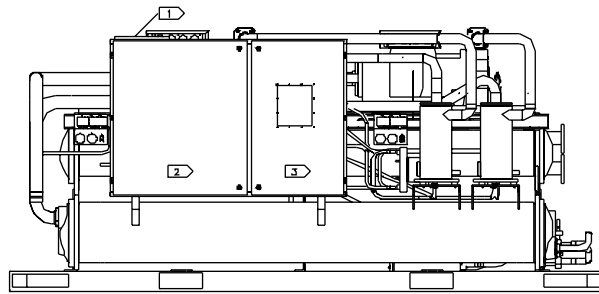
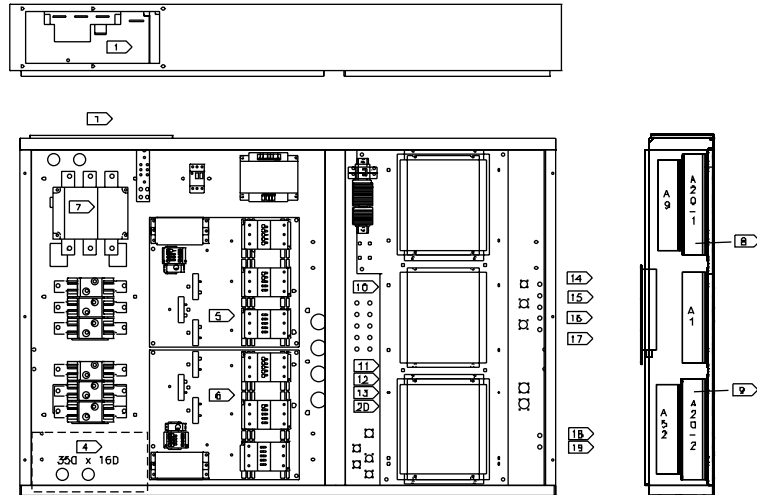

- | | | | |
|----|----|-----|-----|
| 1 | 17 | 102 | 106 |
| 2 | 12 | 102 | |
| 3 | 13 | 105 | |
| 4 | 14 | 102 | |
| 5 | 15 | 101 | 102 |
| 6 | 16 | 104 | 106 |
| 7 | 17 | 103 | 109 |
| 8 | 18 | 103 | |
| 9 | 19 | 104 | |
| 10 | 20 | 105 | |

Dimensions and Weights

RTWB/RTUB 207-224

Evaporator 1 pass

Condenser
(RTWB) 1 pass

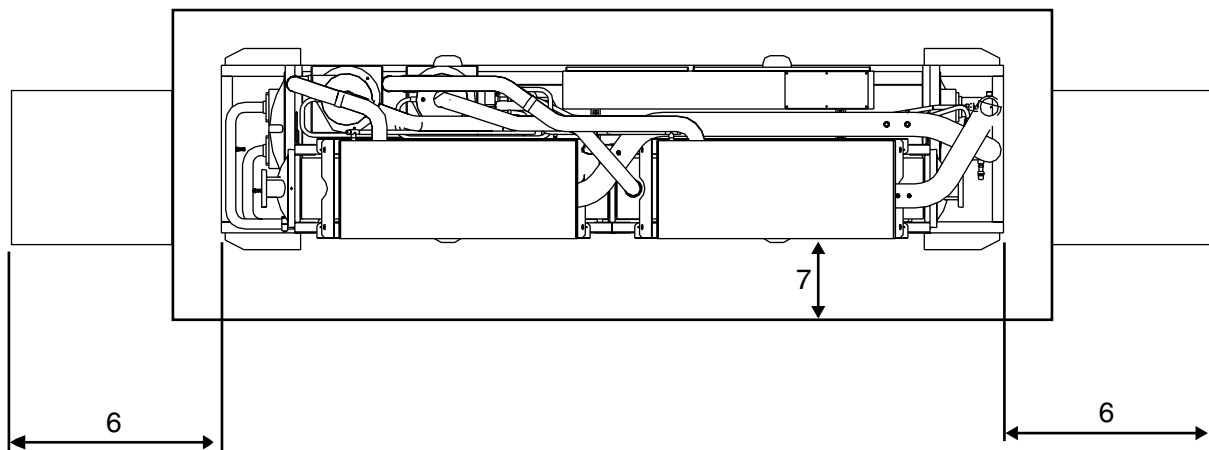
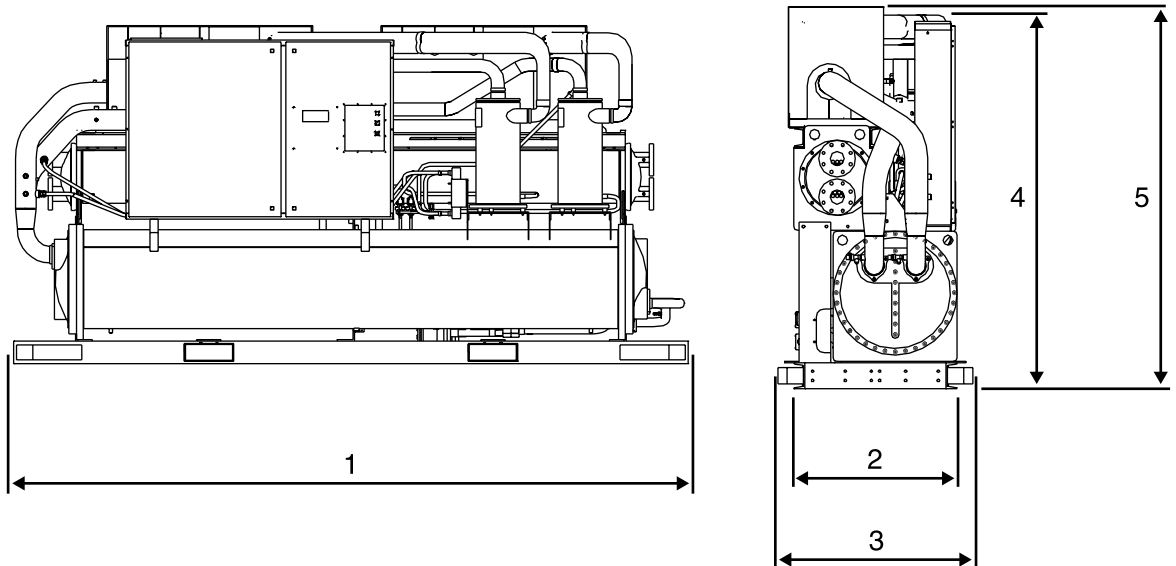

Model	1	2*	3**	4*	5**	6***	7****
RTWB/RTUB	(mm)	(mm)	(mm)	(mm)	(mm)	(mm)	(mm)
207	2880	890	1010	1800	1810	1800	950
208	2880	890	1010	1800	1810	1800	950
210	4150	890	1010	1850	1900	2750	950
211	4150	890	1010	1850	1900	2750	950
212	4150	890	1010	1850	1900	2750	950
214	4150	890	1010	1850	1900	2750	950
216	4150	890	1010	1850	1900	2750	950
217	4150	890	1010	1850	1900	2750	950
218	4150	890	1010	1940	2000	2750	950
220	4150	890	1010	1940	2000	2750	950
222	4150	890	1010	2040	2100	2750	950
224	4150	890	1010	2040	2100	2750	950

(*) With compressor sound enclosure and disconnect-switch handle removed.

(**) With compressor sound enclosure and disconnect-switch handle mounted.

(***) Clearance for retubing: can be on either end of the chiller.

(****) Clearance all around the unit in order to perform usual maintenance operations.

The manufacturer has a policy of continuous product improvement, and reserves the right to alter any details of the products at any time without notice.

This publication is a general guide to install, use and properly maintain our products. The information given may be different from the specification for a particular country or for a specific order. In this event, please refer to your nearest office.

For additional information, contact:

Distributor/Installer stamp



Quality Management System Approval



Trane
A business of American Standard Companies
www.trane.com

For more information contact your local district office or e-mail us at comfort@trane.com

Literature Order Number	RLC-PRC002-E4
Date	10/03
Supersedes	RLC-PRC002-E4_1201
Stocking Location	Europe

Trane has a policy of continuous product and product data improvement and reserves the right to change design and specifications without notice. Only qualified technicians should perform the installation and servicing of equipment referred to in this publication.

Société Trane – Société Anonyme au capital de 61 005 000 Euros – Siège Social: 1 rue des Amériques – 88190 Golbey – France – Siret 306 050 188-00011 – RSC Epinal B 306 050 188
Numéro d'identification taxe intracommunautaire: FR 83 3060501888